



Rewarding Learning

General Certificate of Secondary Education
2019

Centre Number

--	--	--	--	--

Candidate Number

--	--	--	--

Technology and Design

Unit 1:

Technology and
Design Core Content

[GTY11]

FRIDAY 24 MAY, MORNING

MV18

Time

1 hour 30 minutes, plus your additional time allowance.

Instructions to Candidates

Write your Centre Number and Candidate Number in the spaces provided at the top of this page.

You must answer the questions in the spaces provided.

Do not write on blank pages.

Questions which require drawing or sketching should be completed using an H.B. pencil. All other questions must be completed using black ink only.

Do not write in pencil or with a gel pen.

Answer **all ten** questions.

Information for Candidates

The total mark for this paper is 100.

Quality of written communication will be assessed in Question **10**.

Figures in brackets printed at the end of each question indicate the marks awarded to each question or part question.

The Formula sheet is on page 3.

BLANK PAGE
(Questions start on page 4)

Formulae for GCSE Technology and Design

You should use, where appropriate, the formulae given below when answering questions which include calculations.

1 Potential Difference = current \times resistance ($V = I \times R$)

2 Series Resistors $R_t = R_1 + R_2 + \dots + R_n$



3 Gear ratio of a simple gear train = $\frac{\text{number of teeth on driven gear}}{\text{number of teeth on driver gear}}$

4 Velocity ratio = $\frac{\text{diameter of driven}}{\text{diameter of driver}}$

1 **Table 1** refers to a number of symbols.

(a) Using the first row as a guide, complete the table.
[5 marks]

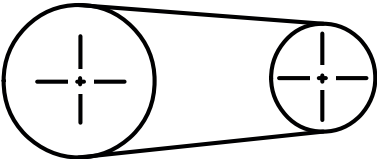
Table 1

Sketch of Symbol	Type of Symbol	Name of Symbol
	Electronic	Bulb
		
	Electronic	
		Diode

(b) **Table 1** shows the symbol for a bulb. This component produces light in an electronic circuit.

(i) Name another electronic component that produces light and classify it as an input, process or output component. [1 mark for each]

Name _____

Classification _____

(ii) Name an electronic component which is controlled by light and classify it as an input, process or output component. [1 mark for each]

Name _____

Classification _____

(c) Fig. 1 shows a pneumatic symbol.

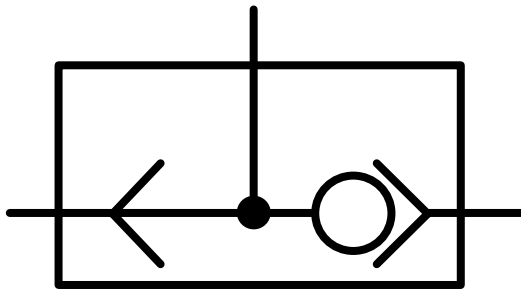

Fig. 1

Name the component represented by this symbol and outline its purpose in a pneumatic circuit.

Name [1 mark] _____

Purpose [2 marks] _____

2 **Fig. 2** shows a Computer Aided Design (CAD) drawing and an outline sketch of a brass component. The brass component is to be produced using a manually operated lathe.

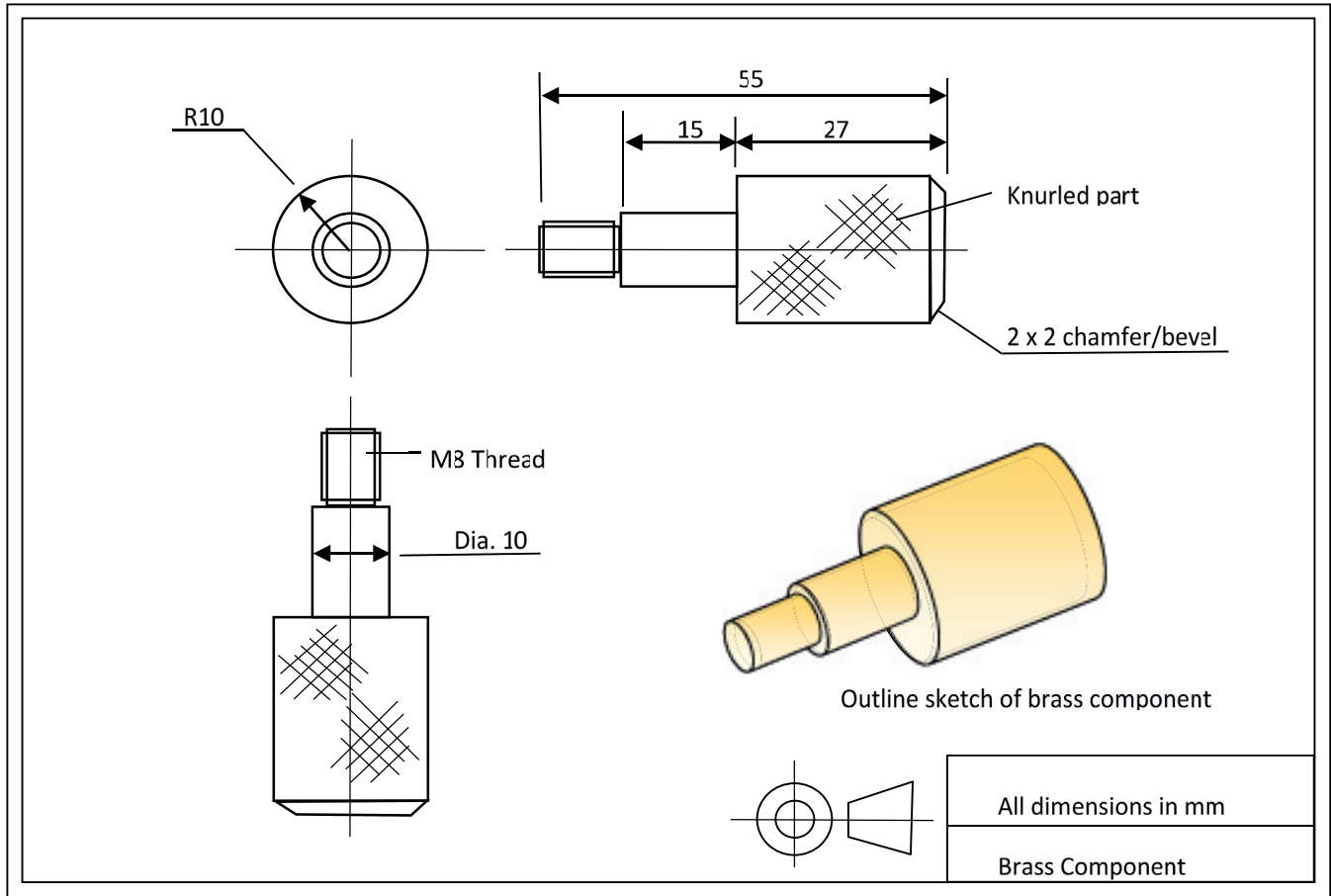

Fig. 2

(a) (i) Brass is an alloy, consisting of two metals. Name the **two** metals used to produce brass. [2 marks]

(ii) Identify **two** properties of brass. [1 mark for each]

1. _____

2. _____

(b) List **two** features of a CAD program. [1 mark for each]

1. _____

2. _____

(c) Look at the brass component in **Fig. 2**. Identify **two** possible processes to be used by a manually operated lathe to produce this component. [1 mark for each]

1. _____

2. _____

(d) The **five** bullet points below describe, in order, the general stages for operating a manual lathe to produce the component shown in **Fig. 2** on page 6. Complete **Fig. 3** on page 9 by **summarising** each of the bullet points as a key factor of each of the remaining stages. [4 marks]

The first bullet point has been done as an example.

- A cylindrical workpiece is inserted in the lathe. A chuck key is used to tighten the workpiece in the chuck.
- The spindle is to rotate at a suitable speed for the material and operation. The spindle speed plays a huge role during cutting. The spindle rotates the chuck and workpiece.
- Check the workpiece is tightened properly in the chuck and the workpiece is rotating centrally. Check the safety guard is secure and appropriate safety equipment is worn.
- Before proceeding with the cutting operation align the cutting tool to the correct starting position. When this is completed, the cutting operation should commence.
- When the machine is turned off, all unwanted metal is removed. Moving the carriage both horizontally and vertically away from the workpiece helps the cleaning process.

Flow chart stages in operating a lathe

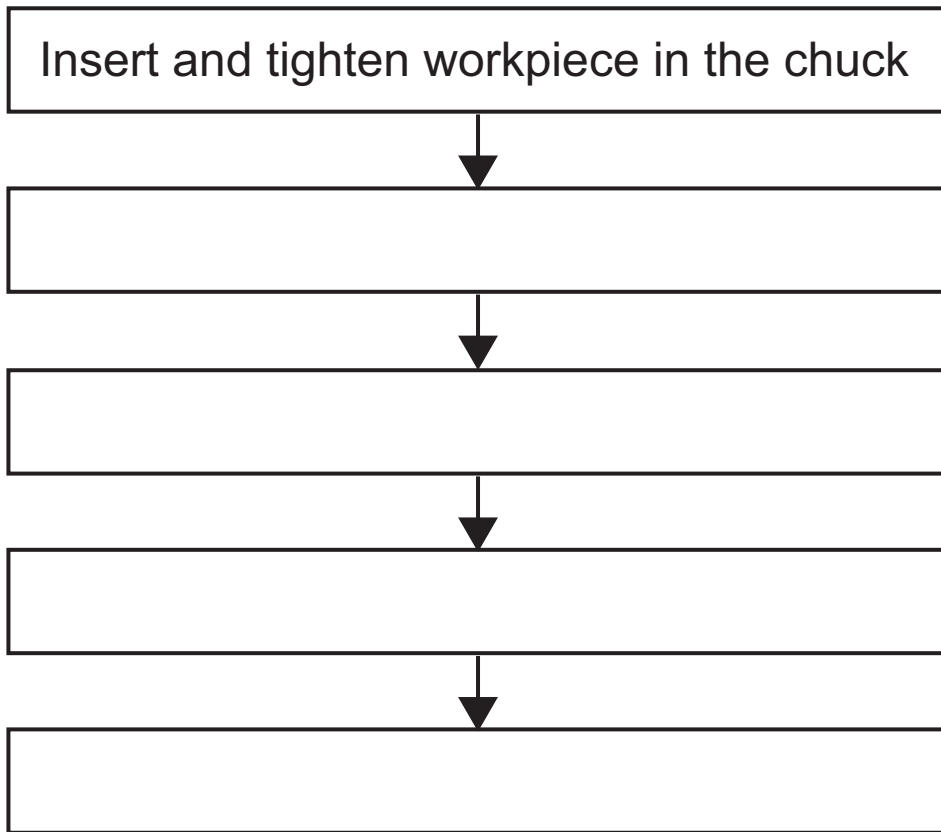

Fig. 3

3 Fig. 4 shows a cam and follower.

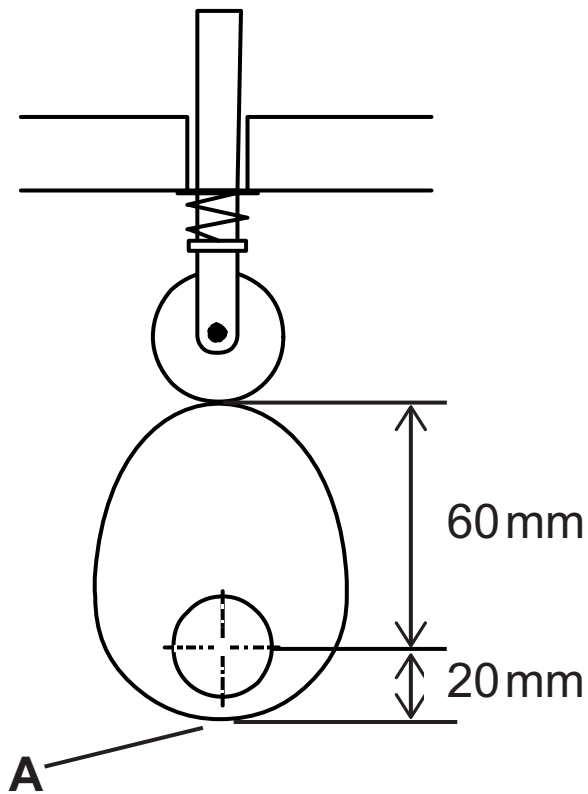

Fig. 4

(a) Select the word from the list below to describe:

- the motion of the cam, and
- the output motion.

Reciprocation

Linear

Rotary

Oscillating

(i) Cam motion [1 mark]

(ii) Output motion [1 mark]

(b) (i) Select the correct name for the cam from the following list. [1 mark]

Eccentric

Heart Shaped

Pear Shaped

Snail

(ii) Determine the direction in which the follower will move if the cam turns until the point **A** is in contact with the follower. [1 mark]

(iii) Determine the distance moved by the follower when the cam turns from this position to the position shown in **Fig. 4**. [2 marks]

4 Fig. 5 shows a pneumatic valve.

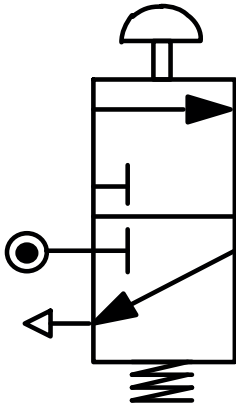

Fig. 5

(a) Name the valve shown in **Fig 5**. [1 mark]

(b) (i) Clearly label the main air supply and the exhaust on **Fig. 5**. [2 marks]

(ii) For the valve shown in **Fig. 5** state:
[1 mark for each]

Method of operation

Method of return

5 (a) The questions below refer to a number of different materials. Place a tick (✓) in the correct box to respond to each question. [5 marks]

- (i)** Is Nylon a thermoplastic or a thermosetting plastic?
- Thermoplastic
 Thermosetting
- (ii)** Is Beech a softwood or a hardwood?
- Softwood
 Hardwood
- (iii)** Is Carbon steel a ferrous or a non-ferrous metal?
- Ferrous
 Non-ferrous
- (iv)** Which of the two metals is an alloy?
- Copper
 Mild Steel
- (v)** Is Plywood a softwood or a manufactured board?
- Softwood
 Manufactured Board

(b) Name the **category** of plastic used in vacuum forming and explain why this type of plastic is used for this process.

Type [1 mark]

Explanation [2 marks]

(c) Name the tool shown in **Fig. 7** and explain what it is used for.



Fig. 7

Name [1 mark]

Use [2 marks]

6 (a) (i) PCBs are commonly used in the construction of electronic circuits.

What do the letters PCB stand for? [1 mark]

(ii) Once designed, a PCB needs to be prepared prior to connecting the electronic components.

Name **two** key processes used to prepare the PCB layout. [2 marks]

1. _____

2. _____

(iii) Describe the purpose of carrying out each of the processes above on the PCB. [2 marks]

- (b) (i)** Name the two electronic components represented by their symbols, labelled **X** and **Y** in **Fig. 8** below.
[1 mark for each]

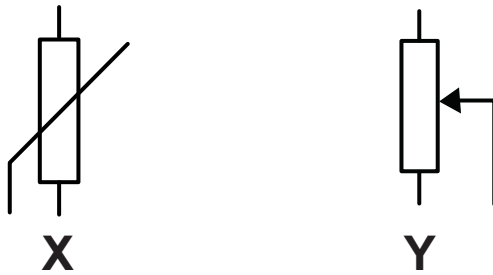

Fig. 8

X _____
Y _____

- (ii)** Name the process used to connect either component to a PCB layout. [1 mark]

BLANK PAGE

(Questions continue overleaf)

- 7 A moisture sensor may be used to detect the moisture of soil around a flower. **Fig. 9** shows a sketch of an electronic moisture sensor and how it may be used.

The circuit in the moisture sensor is to be programmed as follows:

When the moisture sensor probes detect a low level of moisture, it turns on a buzzer for ten seconds. The green LED should then switch on for half a second, followed by a delay of half a second. The red LED switches on for half a second. The whole process should repeat until water is added to the system, but should resume when a low level of moisture is detected again.

Complete the flow chart in **Fig. 10**. [10 marks]

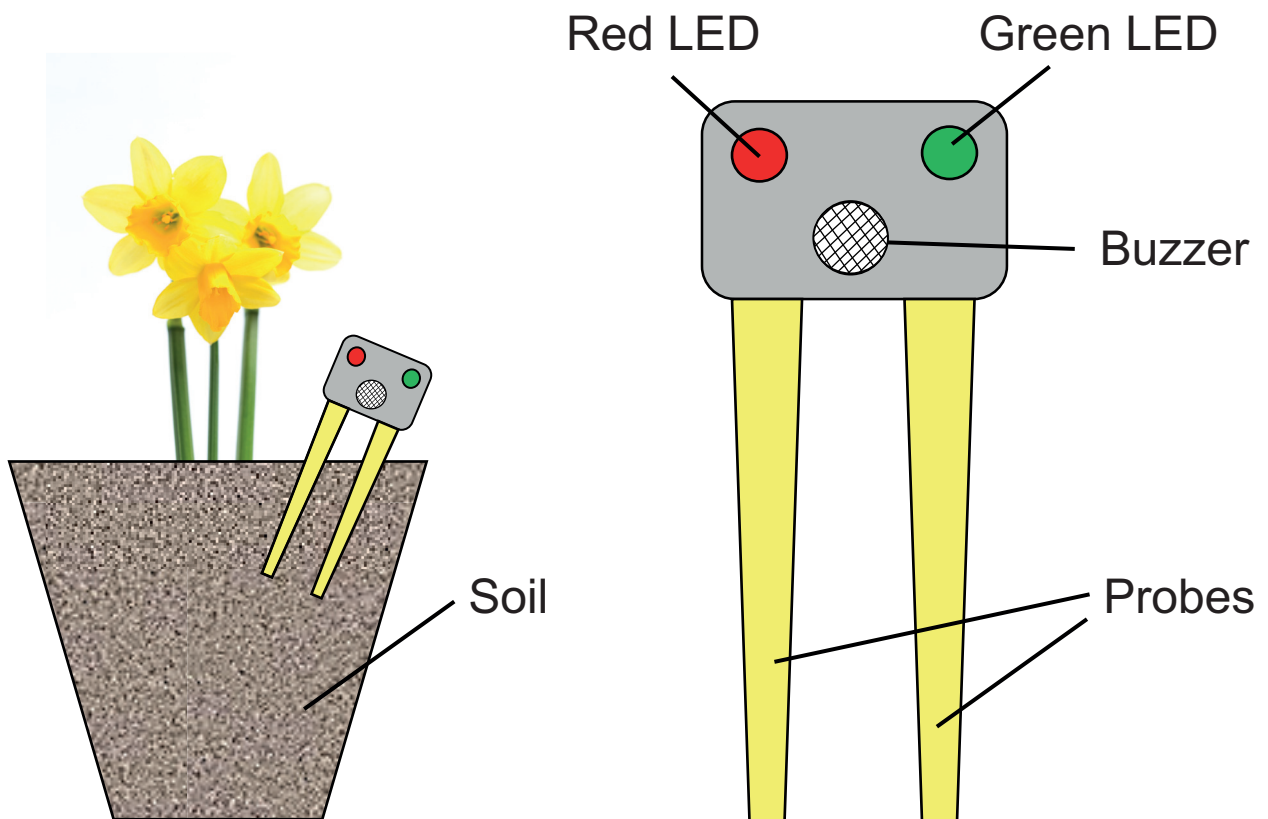

Fig. 9

START

Fig. 10

11866.02 MV18

- 8 (a) Complete **Table 2**, by inserting the name of the transmission system used for the mechanical product.
[2 marks]

Table 2

Mechanical Product	Application	Transmission
Bicycle	To connect the pedals to drive the rear wheel	
Pillar Drill	To rotate the drill chuck	

BLANK PAGE

(Questions continue overleaf)

(b) **Fig. 11** shows a proposed plan view of a toy lorry chassis. The frame is to be made of wood and have four plastic wheels and axles attached. It is to be driven by a small DC motor and two gear wheels.

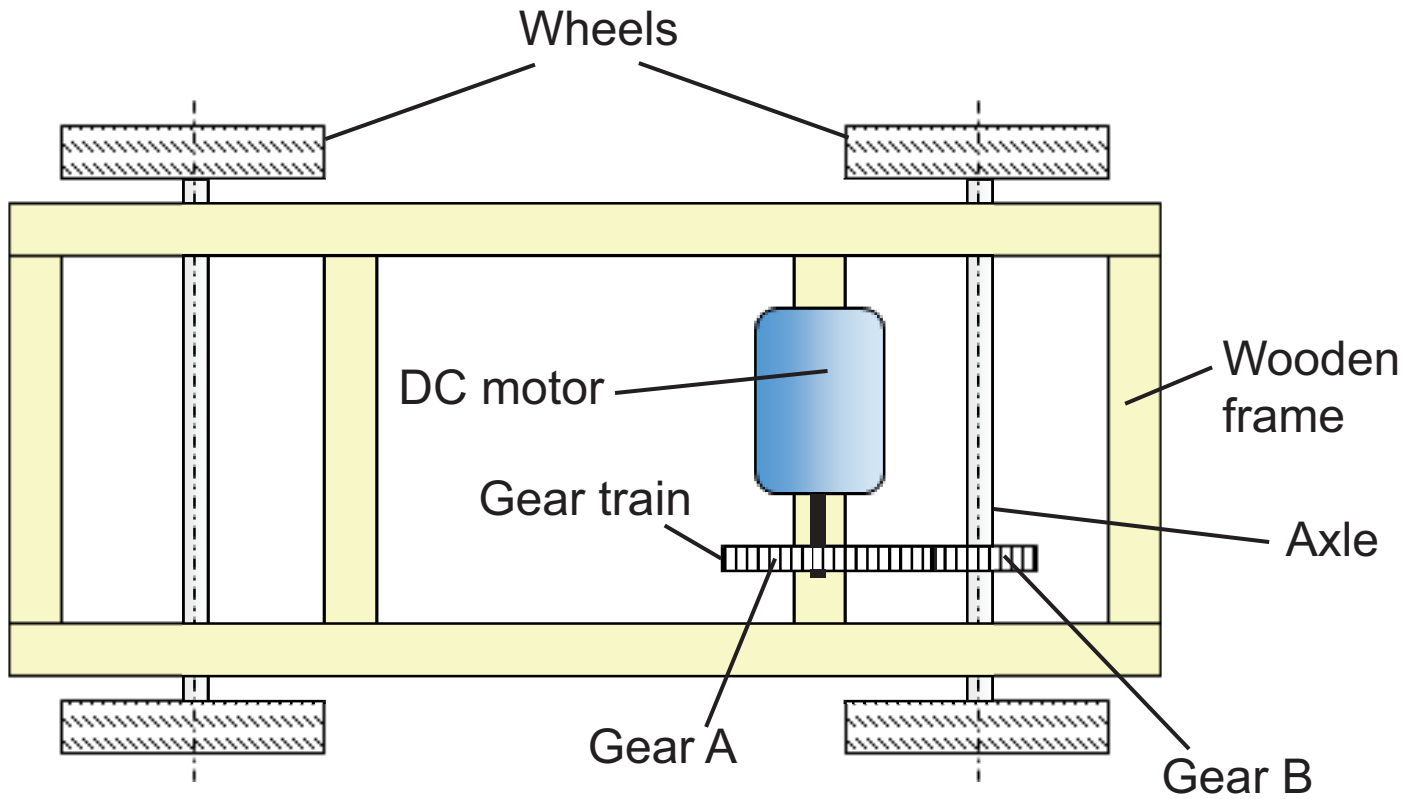

Fig. 11

Fig. 12 represents the gear train used for the lorry. The driver gear **A** attached to the motor rotates in a clockwise direction.

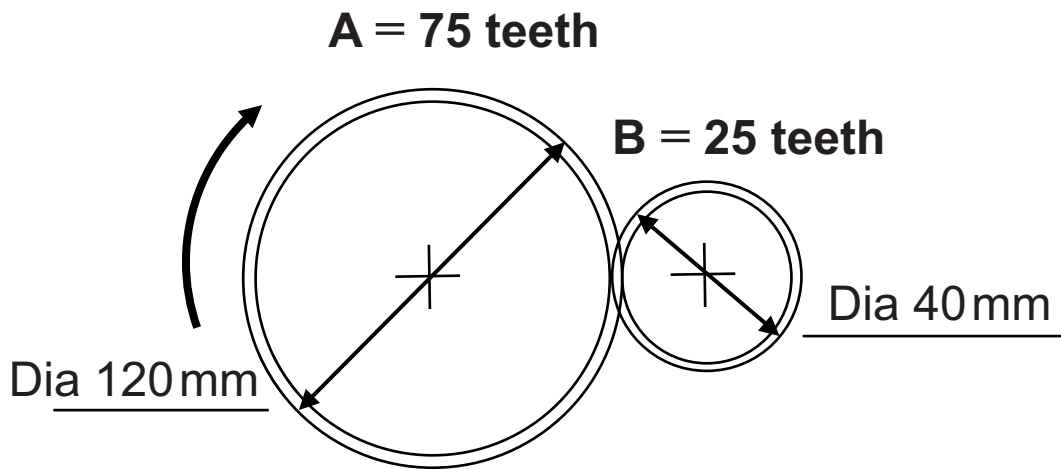

Fig. 12

(i) What name is given to gear **B**? [1 mark]

(ii) Draw on **Fig. 12** the direction of rotation of gear **B**. [1 mark]

(iii) Calculate the gear ratio of the gear train. [2 marks]

Answer _____

(c) (i) When tested it was found the speed of the toy lorry was too fast. Suggest **two** ways to reduce the speed.
[1 mark for each]

- 1. _____
- 2. _____

(ii) It was necessary to amend the position of the motor and gear wheel **A**. They had to be moved towards the middle of the lorry to balance the load. This resulted in gear wheels A and B being separated as shown in **Fig. 13**. Suggest a modification to the gear train to enable the gear train to function again.
[1 mark]

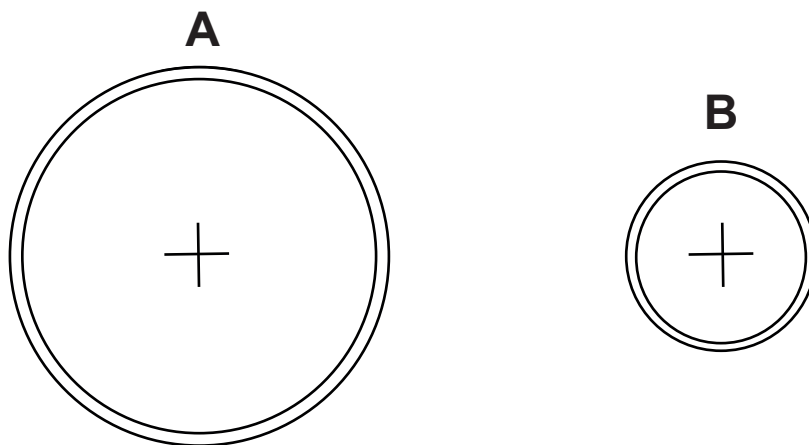

Fig. 13

(iii) How will this change affect the operation of the lorry? [1 mark]

9 (a) (i) Name the pneumatic control symbols shown in **A** and **B** below. [2 marks]



A



B

A _____

B _____

(ii) Explain the function of component **A** in a pneumatic circuit. [2 marks]

(b) Fig. 14 shows a pneumatic circuit used to stamp boxes.

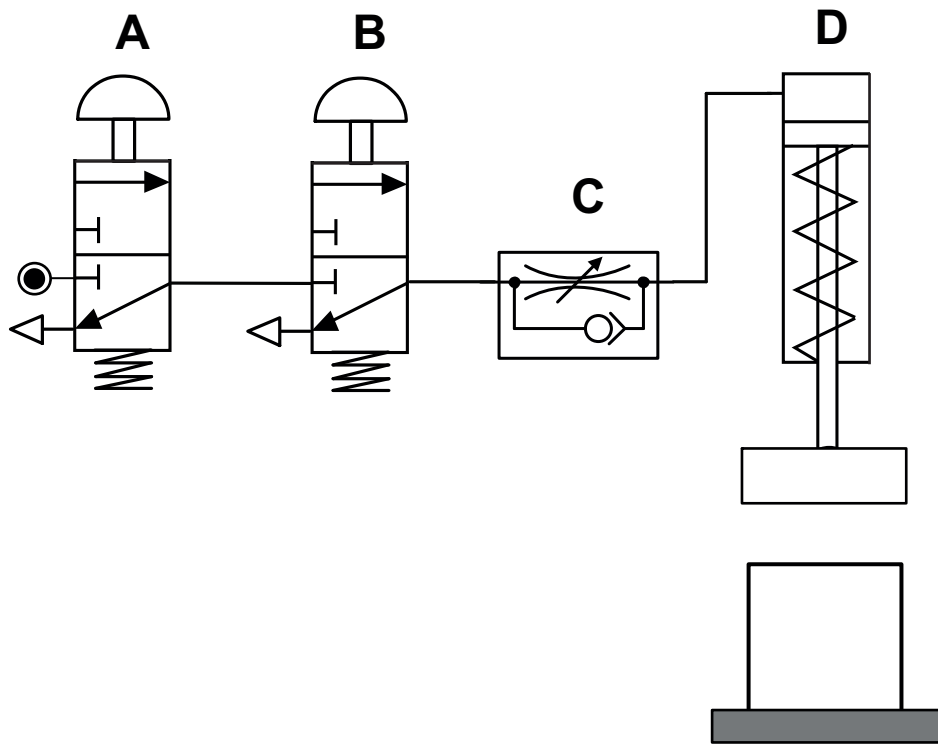

Fig. 14

(i) Describe how the circuit in **Fig. 14** works.
[4 marks]

(ii) Outline **three** safety precautions that should be applied when building the circuit shown in **Fig. 14**.
[3 marks]

THIS IS THE END OF THE QUESTION PAPER

SOURCES

Q2 Source: *Principal Examiner*

Q5(c) Source: *Chief Examiner*

Q7 Source: *Principal Examiner*

Q8(b) Source: *Principal Examiner*

For Examiner's use only	
Question Number	Marks
1	
2	
3	
4	
5	
6	
7	
8	
9	
10	
Total Marks	

Examiner Number

Permission to reproduce all copyright material has been applied for.
In some cases, efforts to contact copyright holders may have been unsuccessful and CCEA will be happy to rectify any omissions of acknowledgement in future if notified.